



Series: IR

INTERCHANGE: With similar couplings
ISO 7241-1 series "A" (size 1/2 only)

MAIN APPLICATIONS

- Agricultural equipment
- Industrial equipment

"IR" is a ball valve quick couplings series, manufactured in carbon steel with zinc plated surface treatment. Based on the good wearing resistance of the ball valves, the "IR" couplings are used mainly in agricultural applications. The 1/2 size will interchange with international standard ISO 7241-1 "A".



Stucchi®

A CONSTANT FLOW OF SOLUTIONS

TECHNICAL FEATURES AND OPTIONS

- Interchangeability: ISO 7241-1 series "A" (size 1/2 only)
- Valve system: Ball valve
- Mechanical connection: Locking balls
- Connection system: Pulling back the sleeve and pushing one half towards the other
- Disconnection system: Pulling back the sleeve
- Connection with residual pressure: Not allowed
- Disconnection with residual pressure: Not allowed
- Threads available: BSP, NPT
- Construction material: Carbon steel
- Surface treatment: CrIII zinc plated
- Springs: C72 steel
- Balls: Hard steel 100 C6
- Seals: standard in NBR (Nitrile)

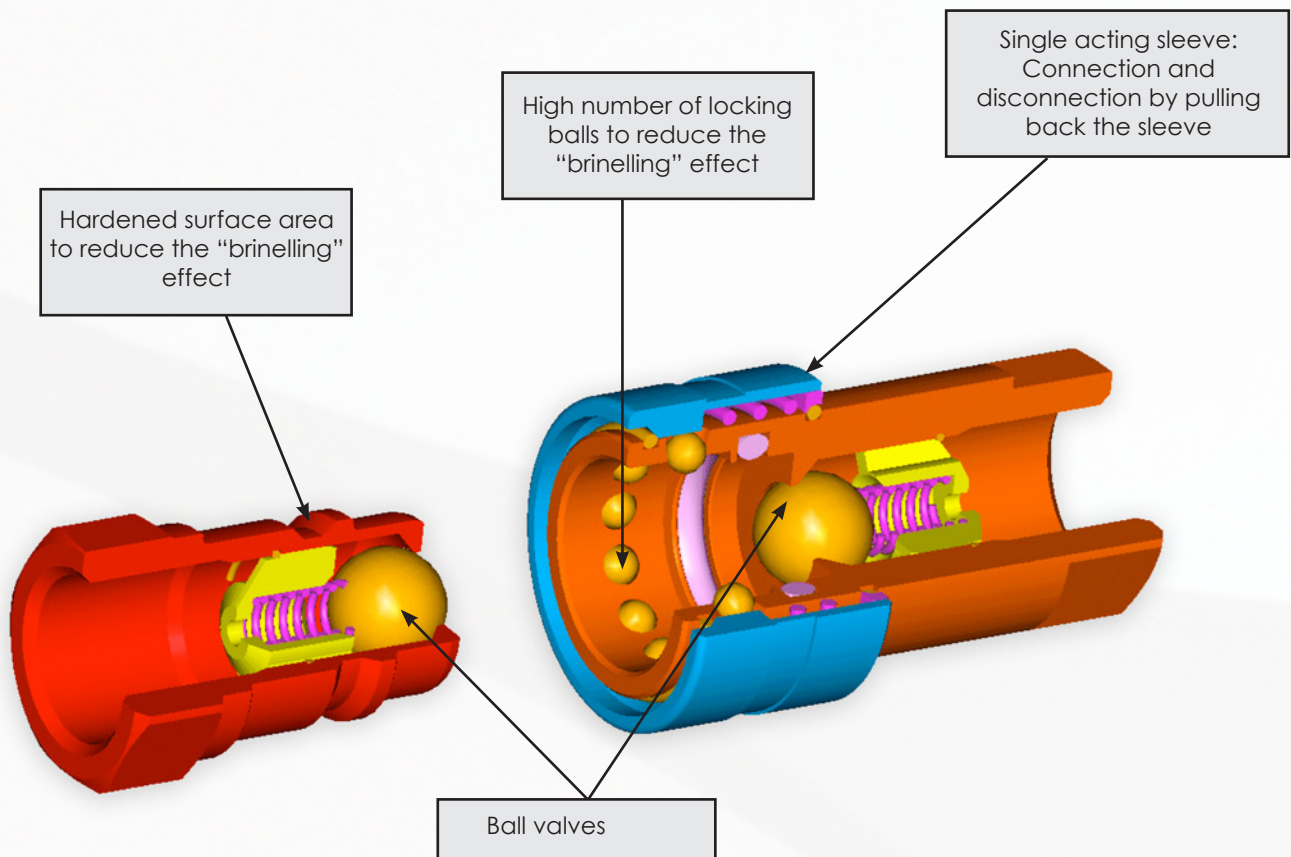

BENEFITS

- Ball valves in hardened steel provide a good wearing resistance.
- Compact slim design.
- Simple to use.

HOW TO USE

- Before connecting clean the mating parts of the couplings to avoid contamination in the circuit.
- To couple pull back the sleeve of the female coupling, align the female with the male coupling and push one into the other until both halves are fully connected and release the sleeve.
- To uncouple pull back the sleeve of the female coupling, pull out the mating half.

WARNING!

- Do not couple-uncouple with flow and/or pressure in the circuit.
- Use protection whenever connecting or disconnecting with high temperature (max. allowed 80°C, 176 °F).
- When the couplings are disconnected, it is suggested to use the protection caps.

PERFORMANCE

Description	Size	ISO Size	Rated flow		Max. flow suggested		Connect force		Disconnect force		Spillage *
			l/min	GPM	l/min	GPM	N	lbf	N	lbf	
	Inch	mm									ml
IR14	1/4	-	12	3,18	20	5,30	50	11,25	45	10,13	0,13
IR38	3/8	-	23	6,10	46	12,19	125	28,13	45	10,13	0,45
IR12	1/2	12,5	45	11,93	90	23,85	80	18,00	50	11,25	2,30
IR34	3/4	-	74	19,61	148	39,22	190	42,75	45	10,13	4,50
IR100	1	-	100	26,50	150	39,75	100	22,50	45	10,13	6,00

Description	Max. operating pressure						Burst pressure					
	Coupled		Male		Female		Coupled		Male		Female	
	MPa	psi	MPa	psi	MPa	psi	MPa	psi	MPa	psi	MPa	psi
IR14	30	4350	30	4350	30	4350	100	14500	100	14500	100	14500
IR38	30	4350	30	4350	30	4350	100	14500	100	14500	90	13050
IR12	25	3625	20	2900	20	2900	80	11600	55	7975	55	7975
IR34	25	3625	20	2900	25	3625	100	14500	60	8700	90	13050
IR100	20	2900	20	2900	20	2900	80	11600	60	8700	80	11600

* Spillage is an indicative value of the fluid loss per couple-uncouple cycle.

- Temperature range:
- Standard seals NBR (Nitrile): from -20 °C to +100 °C (from -4 °F to +212 °F).

PRESSURE DROP

TESTS ESEGUITI IN CONFORMITA' A ISO 7241-2
 TESTS IN ACCORDANCE WITH ISO 7241-2

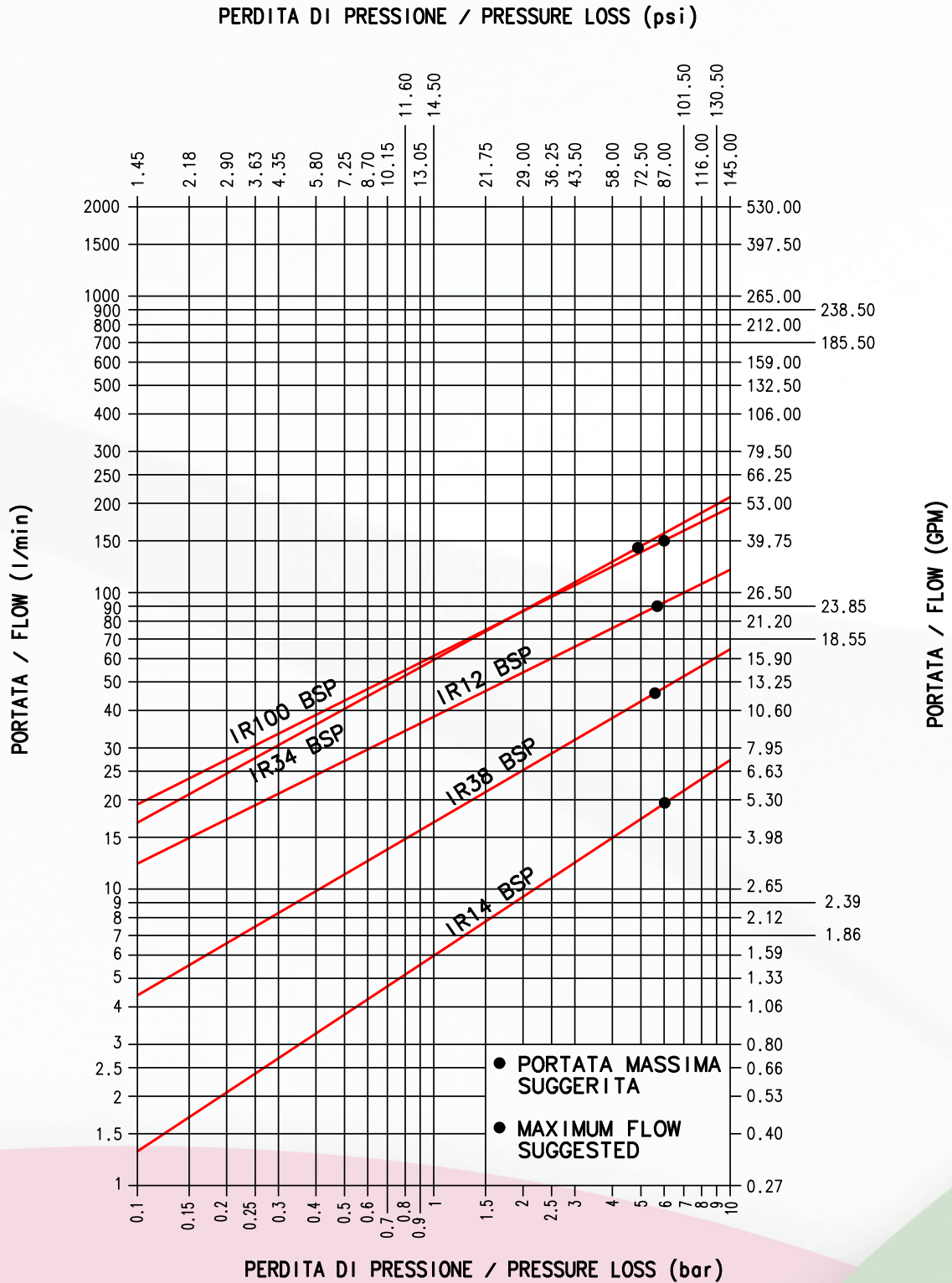

FLUIDO: OLIO ISO VG32
 TEMPERATURA: 40°C
 VISCOSITA': 28.8-35.2 mm²/s

FLUID: OIL ISO VG32
 TEMPERATURE: 40°C
 VISCOSITY: 28.8-35.2 mm²/s

OVERALL DIMENSIONS

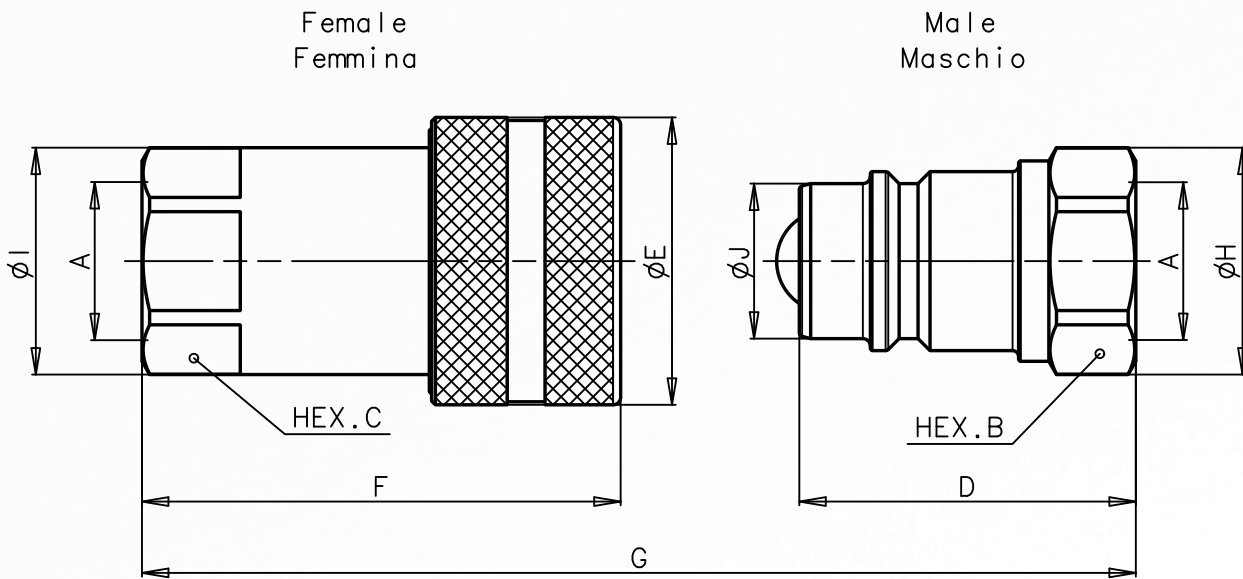

FEMALE BSPB THREAD (DIN 3852)

Description	A	Unit	B	C	D	E	F	G	H	I	J	Unit	Weight	
													Male	Female
IR14 BSP	1/4	mm Inch	19 0,75	19 0,75	32,5 1,28	27 1,06	48,9 1,93	64,4 2,54	22 0,87	21 0,83	14,2 0,56	Kg lb	0,038 0,08	0,113 0,25
IR38 BSP	3/8	mm Inch	24 0,94	24 0,94	38 1,50	34 1,34	58,3 2,30	76,3 3,00	27,7 1,09	26,5 1,04	19 0,75	Kg lb	0,078 0,17	0,220 0,49
IR12 BSP	1/2	mm Inch	27 1,06	27 1,06	44,5 1,75	38 1,50	63,3 2,49	86,3 3,40	30 1,18	30 1,18	20,5 0,81	Kg lb	0,097 0,21	0,244 0,54
IR34 BSP	3/4	mm Inch	36 1,42	38 1,50	59 2,32	48 1,89	90,3 3,56	118,3 4,66	38,5 1,52	43 1,69	26,9 1,06	Kg lb	0,193 0,43	0,681 1,50
IR100 BSP	1	mm Inch	41 1,61	45 1,77	66,1 2,60	54 2,13	99,6 3,92	132,8 5,23	44,8 1,76	52 2,05	31,4 1,24	Kg lb	0,300 0,66	0,870 1,92

FEMALE NPT THREAD (ANSI B.1.20.3)

Description	A	Unit	B	C	D	E	F	G	H	I	J	Unit	Weight	
													Male	Female
IR14 NPT	1/4	mm Inch	19 0,75	19 0,75	32,5 1,28	27 1,06	48,9 1,93	64,4 2,54	22 0,87	21 0,83	14,2 0,56	Kg lb	0,040 0,09	0,125 0,28
IR38 NPT	3/8	mm Inch	24 0,94	24 0,94	38 1,50	34 1,34	58,3 2,30	76,3 3,00	27,7 1,09	26,5 1,04	19 0,75	Kg lb	0,080 0,18	0,222 0,49
IR12 NPT	1/2	mm Inch	27 1,06	27 1,06	44,5 1,75	38 1,50	63,3 2,49	86,3 3,40	30 1,18	30 1,18	20,5 0,81	Kg lb	0,090 0,20	0,277 0,61
IR34 NPT	3/4	mm Inch	36 1,42	38 1,50	59 2,32	48 1,89	90,3 3,56	118,3 4,66	38,5 1,52	43 1,69	26,9 1,06	Kg lb	0,211 0,47	0,699 1,54
IR100 NPT	1	mm Inch	41 1,61	45 1,77	66,1 2,60	54 2,13	99,6 3,92	132,8 5,23	44,8 1,76	52 2,05	31,4 1,24	Kg lb	0,301 0,66	0,894 1,97

PROTECTION CAPS FOR IR-V AND IR SERIES

Protective caps are always recommended to protect the couplings from damage or dirt inclusion, and increase the product life. This is particularly important in mobile applications where contamination can enter the coupling and compromise the function. The caps for BIR, IR-V and IR series are manufactured in PVC rubber and they are available in several colors.



OVERALL DIMENSIONS PROTECTION CAPS FOR IR-V AND IR SERIES

CAP FOR MALE COUPLING
Tappo per innesto maschio

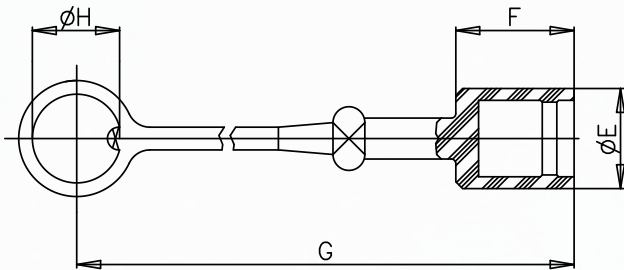

CAP FOR FEMALE COUPLING
Tappo per innesto femmina

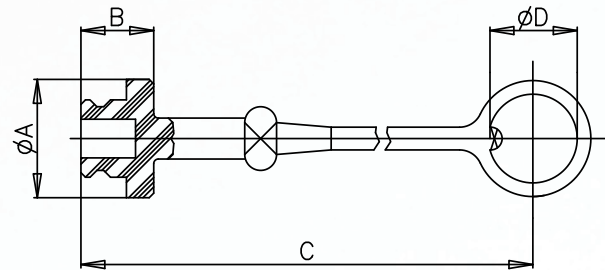

PVC CAPS

- Available in following colors: Red, yellow, blue, black and green.
- Temperature range: from -20 °C to +100 °C (from -4 °F to +212 °F).

Description	Coupling	Unit	A	B	C	D	E	F	G	H	Unit	Weight
T.M. 1/4	F-IR14	mm	26	16	223	19,5	-	-	-	-	Kg	0,018
	F-IR14V	Inch	1,02	0,63	8,78	0,77	-	-	-	-	lb	0,04
T.F. 1/4	M-IR14	mm	-	-	-	-	22	26	233	19,5	Kg	0,017
	M-IR14V	Inch	-	-	-	-	0,87	1,02	9,17	0,77	lb	0,04
T.M. 3/8	F-IR38	mm	30	18	225	25,5	-	-	-	-	Kg	0,032
	F-IR38V	Inch	1,18	0,71	8,86	1,00	-	-	-	-	lb	0,07
T.F. 3/8	M-IR38	mm	-	-	-	-	27	29	236	25,5	Kg	0,024
	M-IR38V	Inch	-	-	-	-	1,06	1,14	9,29	1,00	lb	0,05
T.M. 1/2	F-IR12	mm	33	20	273	28	-	-	-	-	Kg	0,020
	F-BIR12	Inch	1,30	0,79	10,75	1,10	-	-	-	-	lb	0,04
T.F. 1/2	M-IR12	mm	-	-	-	-	29	32	239	28	Kg	0,022
	M-BIR12	Inch	-	-	-	-	1,14	1,26	9,41	1,10	lb	0,05
T.M. 3/4	F-IR34	mm	40	25	272	32	-	-	-	-	Kg	0,024
	F-IR34V	Inch	1,57	0,98	10,71	1,26	-	-	-	-	lb	0,05
T.F. 3/4	M-IR34	mm	-	-	-	-	35	42	289	32	Kg	0,019
	M-IR34V	Inch	-	-	-	-	1,38	1,65	11,38	1,26	lb	0,04
T.M. 1	F-IR100	mm	44	24	271	38	-	-	-	-	Kg	0,041
	F-IR100V	Inch	1,73	0,94	10,67	1,50	-	-	-	-	lb	0,09
T.F. 1	M-IR100	mm	-	-	-	-	40	47	294	38	Kg	0,037
	M-IR100V	Inch	-	-	-	-	1,57	1,85	11,57	1,50	lb	0,08